



LR400-3D08

LR400-3D12

LR400-3D16

Dual Pump Controller Manual

Contents

| | | |
|-------|--|----|
| 1 | Health & Safety | 1 |
| 1.1 | Health & Safety at Work, etc. ACT 1974 | 1 |
| 2 | Declaration of Conformity | 1 |
| 3 | General Description & Operation..... | 2 |
| 4 | Recommendations | 2 |
| 5 | Caring for the Environment..... | 2 |
| 5.1 | Disposal of packing material..... | 2 |
| 5.2 | Disposal of your old appliance | 2 |
| 6 | Specification..... | 3 |
| 7 | Features & Operation | 4 |
| 7.1 | External Features | 4 |
| 7.2 | Internal Features | 7 |
| 8 | Operational Features..... | 11 |
| 8.1 | Float Switch Operation..... | 11 |
| 8.2 | Alarm Features | 11 |
| 8.2.1 | High Level Alarm | 11 |
| 8.2.2 | Pump Over Current..... | 12 |
| 8.2.3 | Float switch Fault..... | 12 |
| 8.2.4 | Pump Output Relay Fused Fault..... | 13 |
| 9 | Installation Diagram..... | 13 |
| 10 | Mounting the Product | 16 |
| 11 | Contact Details | 18 |

1 Health & Safety

These warnings are provided in the interest of safety. You must read them carefully before installing or using the equipment.

- Installation of this product should be carried out by a competent person.
- Power isolation: before removing the cover, ensure the incoming mains supply is switched off.
- The MAINS input to the isolator will be HAZARDOUS LIVE unless isolated, regardless of the isolator status.

1.1 Health & Safety at Work, etc. ACT 1974

Regard should be taken of IEE Wiring Regulations, Codes of Practice, Statutory Requirements, and any specific instructions issued by the supplier of these details.

- **EARTHING:** All Equipment must be earth-bonded per the latest IEE Wiring Regulations. For clarity, this has not been shown. We reserve the right to alter these details without prior notice.

2 Declaration of Conformity

The product meets all the essential safety requirements of the relevant European Directives.

The full text of the Declaration of Conformity is available upon request.

3 General Description & Operation

The LR400-3Dxx Pump Controller controls and monitors two pumps within a pump station for water, wastewater, sewerage and other liquids.

The unit monitors float switch inputs to determine pump operation. Protection is provided by monitoring the current to each pump and optional over-temperature sensor inputs.

4 Recommendations

- It is not recommended to install this unit directly outside without a rain cover. If the unit is to be installed outside, it should be installed within a kiosk.
- It is recommended to protect the unit by installing an MCB on the incoming mains power.

5 Caring for the Environment

5.1 Disposal of packing material

The packaging is designed to protect the product from damage during transportation.

The packaging materials used are selected from environmentally friendly materials for disposal and should be recycled.

5.2 Disposal of your old appliance



Electronic and electrical appliances contain many valuable materials. They also contain certain materials, compounds and components which were essential for their correct functioning and safety. These could be hazardous to your health and to the environment if disposed of with general waste or if handled incorrectly. Please do not dispose of your old product with your household waste.

6 Specification

| | Rating |
|---|--|
| Enclosure IP Rating Material Dimensions Weight | IP65 Polycarbonate W380mm x h280mm x d170mm 3kg |
| Supply Voltage | I 240V Single-phase III 400V three-phase |
| Pump Output Current | 3D08 8A max each pump 3D12 12A max each pump 3D16 16A max each pump |
| Pump Protection | <ul style="list-style-type: none"> ▪ Overcurrent trip ▪ Alternating pumps ▪ Contactor fault detection ▪ Over-temperature trip [optional extra] |
| Over-current Setting Range | 1-20A each pump |
| Float Switch Input Switched voltage Maximum switched current Maximum cable length | <i>[Works with any switched input]</i> 3.3Vdc 10mA 200m |
| Audio Output Maximum sound level | 105dB 3Khz 12Vdc |
| Visual Alarm Output | Red flashing LED |
| Alarm Output Relay Relay topology Max Current Max Voltage | COM/NO/NC SPDT 1A @ 250Vac 250Vac |
| Auxiliary Alarm Output Voltage Max Current | 12Vdc 250mA |
| Ambient Temperature | -10°C to +55°C |
| Conformance | EN 61010-1 EN 61000-6-1 EN 61000-6-2 EN 61000-6-3 EN 61000-6-4 |

7 Features & Operation

7.1 External Features

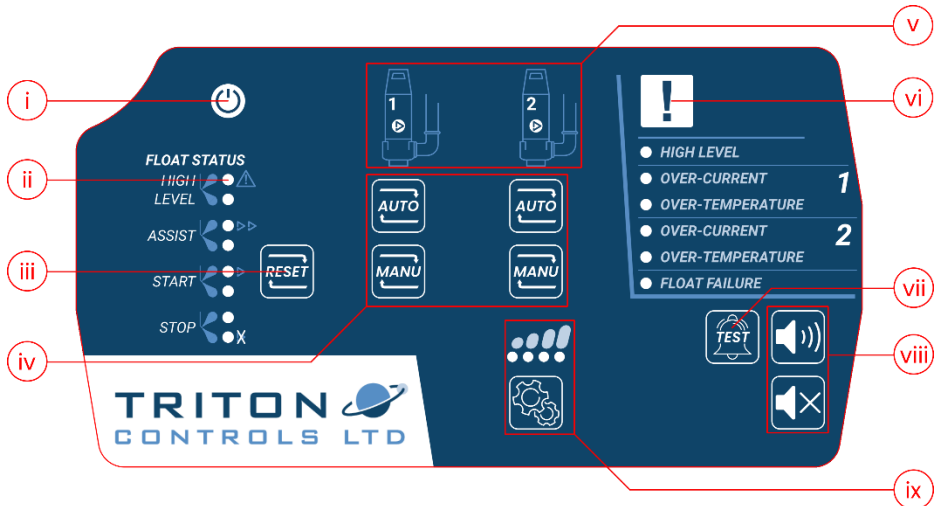

i) **Power Indicator:**

- POWER ON: The indicator will be constantly illuminated
- POWER OFF: The indicator will not be illuminated

ii) **Float Switch Status Indicators:**

The indicators are illuminated with the position of the relevant float switch.

NOTE: This operation is based on a three-wire float switch, with the blue wire inserted into the blue terminal. The pump controller will operate using a two-wired float switch.



HIGH



FLOAT NOT
DETECTED



LOW



FLOAT FAULT

iii) Reset Button:

The reset button [RST] resets all AUTO button positions to OFF and all fault conditions to normal state.

The reset button will also reset the MUTE/UNMUTE audio alarm to UNMUTE.

iv) AUTO/MANU Buttons:

- The MANU button is a momentary button that deactivates the AUTO button and activates its respective pump regardless of any fault condition. The MANU button is illuminated when pressed.
- The AUTO button is a latching button. Its status is stored in the unit's memory. This allows the unit to resume its previous status in the event of a power outage. The AUTO button allows the respective pump to operate depending on the float switch positions.

v) Pump Status Indicators:

- Flashes blue when the pump is to be switched ON
- Illuminated constant blue when the pump is running
- Illuminated red if there is a fault with the pump
- Flashes red if the contactor is faulty **[immediately isolate power if this occurs!]**

NOTE: An activated pump takes 5 seconds before switching ON, during this time, the pump running indicator will flash blue.

vi) Alarm Status Indicators:

- The alarm icon will flash red in the event of an alarm activation
- The activated alarm will be indicated with a constant illuminated red light
- A flashing illuminated light status indicates that an alarm activation previously occurred. This is reset when the RESET button is pressed

vii) Test Button:

The test button is used to quickly test the alarm functionality. The test activates the following:

- The alarm indicator
- Audio alarm output [if it is not in a muted state]
- Beacon output
- Fault relay output
- *Upgrade fault outputs i.e. GSM, Additional Fault relays, etc.*

viii) Mute & Unmute Buttons:

- The UNMUTED button is illuminated blue when activated, allowing the audio alarm to sound in the event of an alarm activation
- The MUTE button is latching and illuminated red when activated
- In the event of a power outage, the status of the mute buttons is stored in memory and will revert to the previous state.

ix) Setup & GSM Signal Strength

- The Setup button is for advanced configurations and communications to the service App.
- The signal strength of the GSM upgrade is displayed on the front of the unit.

7.2 Internal Features

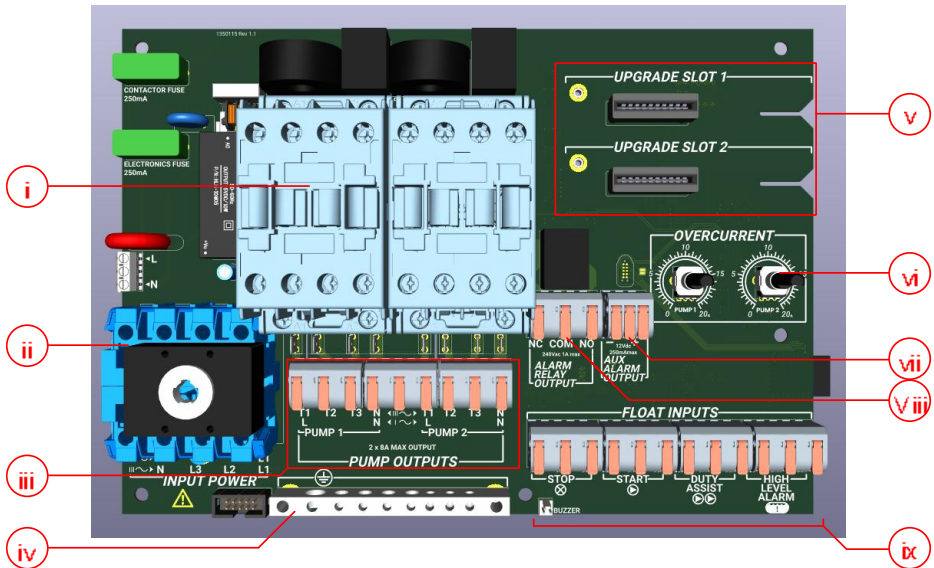

i) Contactors

The contactors are what directly switch the pumps on and off. They are serviceable parts which can be removed and replaced if necessary.

NOTE: The contactors may differ from the image above depending on the model of LR400.

ii) Mains Input Connector & Isolator:

This is a locking isolator whereby the front cover cannot be opened without switching the isolator OFF.

WARNING: Even with the isolator in the OFF position, the incoming mains on the isolator will still be HAZARDOUS LIVE!

iii) Pump Outputs:

The pump outputs control each pump on and off. Depending on the float switch levels, the contactors are electronically controlled to alternate and switch on when required.

Single-Phase Pump

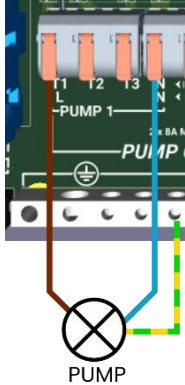

Three-Phase Star Pump

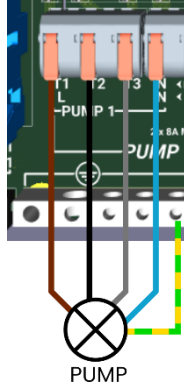

Three-Phase Delta Pump

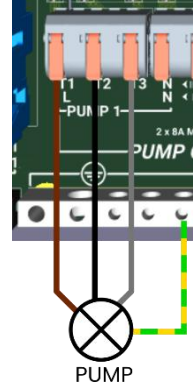

iv) Earth Terminal:

The earth terminal is a brass bar that is used to earth the internal electronics and earth any external part of the pumping system, such as a pump.

v) Upgrade Ports:

Additional features are available via the upgrade ports. These features include the following:

- Over-temperature alarm inputs
- Alarm backup battery
- Additional alarm relay outputs
- GSM Alarm module
- SCADA module

NOTE: Instructions for each module are supplied with the module installed or supplied

vi) Over Current Setup:

The overcurrent dials set each pump's current limit. Once an overcurrent fault is triggered, the unit will not reset until the reset button is pressed or the unit is powered off.

vii) Beacon Output:

The beacon output is activated in the event of an alarm. A 12Vdc signal is produced to operate a beacon. The output can produce a maximum current of 250mA.

viii) Alarm Output Relay

The volt-free relay output is activated in the event of an alarm or test.

ix) Float Switch Inputs:

The float switch inputs can monitor all 3 cables of the float switch. This allows the unit to display the full status of the float switch on the front of the panel.

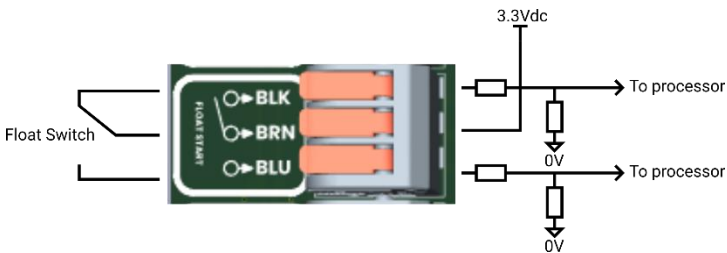
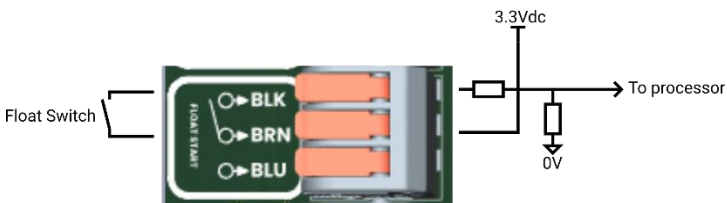
3-Wire Configuration:**2-Wire Configuration:**

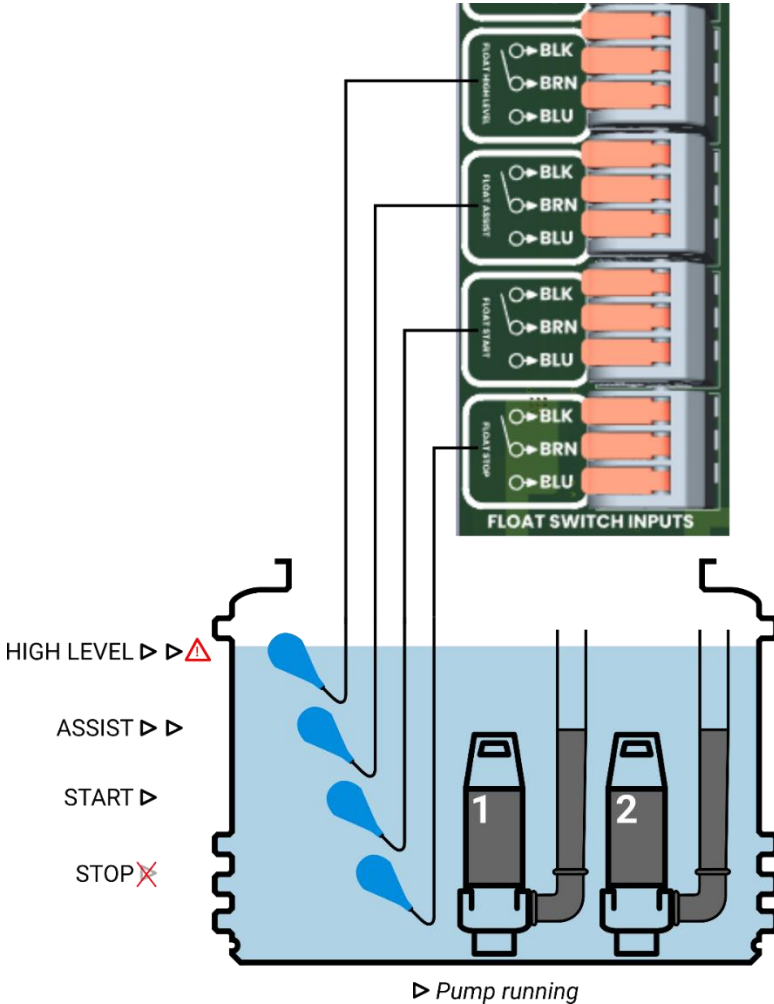

| Float Switch | Position | Control (rising level) | Control (Falling level) |
|--------------|----------|------------------------|-------------------------|
| HIGH LEVEL | HIGH | ▷▷ ⚠️ | ▷▷ ⚠️ |
| ASSIST | HIGH | ▷▷ | ▷▷ |
| START | HIGH | ▷ | ▷ |
| STOP | HIGH | Pumps OFF | ▷ |
| STOP | LOW | Pumps OFF | Pumps OFF |

NOTE: The pumps alternate on activation.

8 Operational Features

8.1 Float Switch Operation

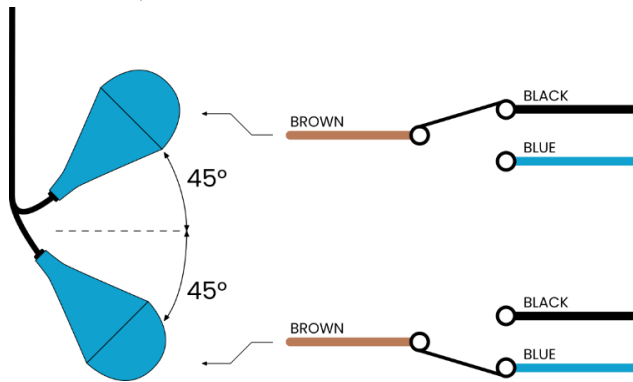

NOTE: Different manufacturers may have different variations of wiring colours. Check the wiring before installation.

8.2 Alarm Features

8.2.1 High Level Alarm

EVENT:

The brown & black contacts of the high-level float switch are in a closed-circuit state with the brown & blue contacts in an open-circuit state.

UNIT RESPONSE:

- The unit will go into an alarm state
- The fault relay and beacon output will activate
- The high-level indicator will be illuminated constantly red

UNIT RECOVERY:

Once the high level state of the float switch returns to low level, the unit will deactivate the alarm. The high level indicator will flash, signifying a high level has occurred. This can be cleared using the reset button.

8.2.2 Pump Over Current

EVENT:

A pump is running, and the controller detects a current greater than the set current limit.

UNIT RESPONSE:

- The unit will go into an alarm state
- The fault relay and beacon output will activate
- The respective over-current indicator will illuminate a constant red
- The respective pump will be switched OFF

UNIT RECOVERY:

The unit must be reset to recover from the alarm state

8.2.3 Float switch Fault

EVENT:

The controller has detected a closed circuit between the brown & blue contacts and the brown and black contacts of a float switch.

UNIT RESPONSE:

- The unit will go into an alarm state
- The fault relay and beacon output will activate
- Both float state indicators will flash for the respective faulty float
- The fault float switch shall be excluded from pump control operation

8.2.4 Pump Output Relay Fused Fault

EVENT:

If a pump is switched OFF and the controller detects a current greater than 4A flowing through to the pump, the controller will go into an alarm state.

UNIT RESPONSE:

- The unit will go into an alarm state
- The fault relay and beacon output will activate
- The respective pump status indicator will flash red
- The respective over-current & over-temperature indicators will flash red

WARNING: For this fault, the controller is unable to switch the pump off. The controller must be isolated from mains power immediately.

9 Installation Diagram

Float Switch Wiring:

3 Wire float switches:

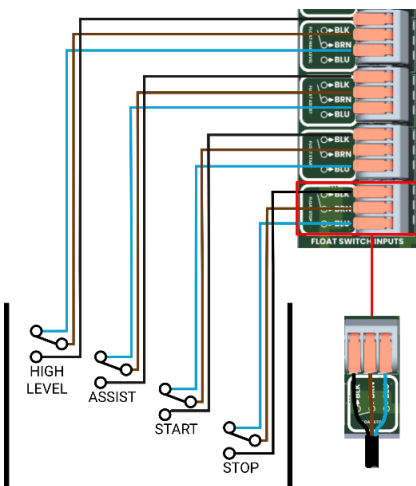

For full float diagnostics, ensure all three wire colours are connected into the input terminals.

2 Wire float switches:

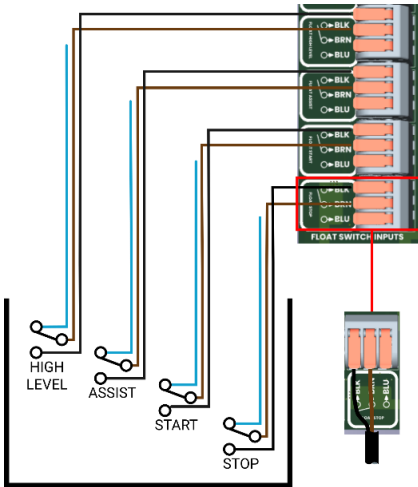

For 2-wire float switch operations, ensure the blue wires of each float are safely isolated.

DO NOT combine the blue wires.

Mains Wiring:

THREE PHASE – Delta pumps:

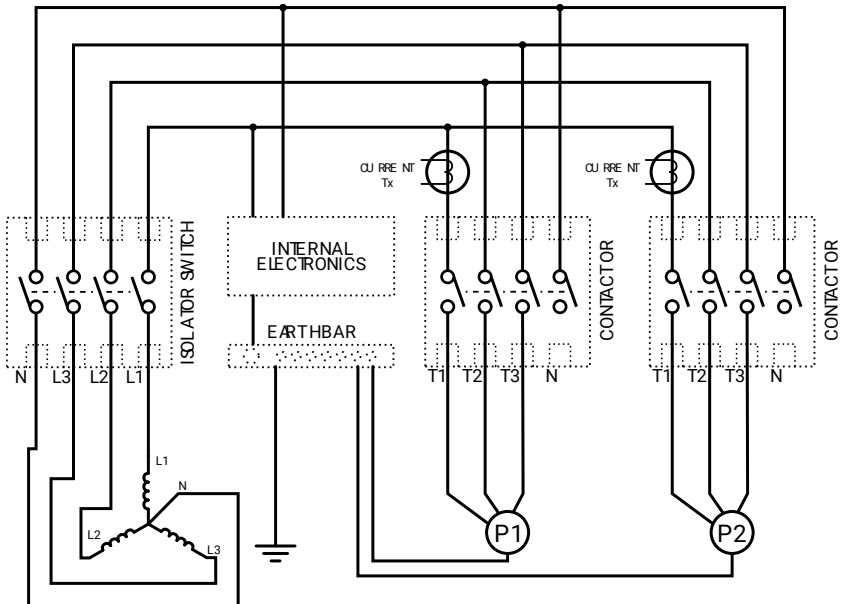

THREE PHASE – Star pumps:

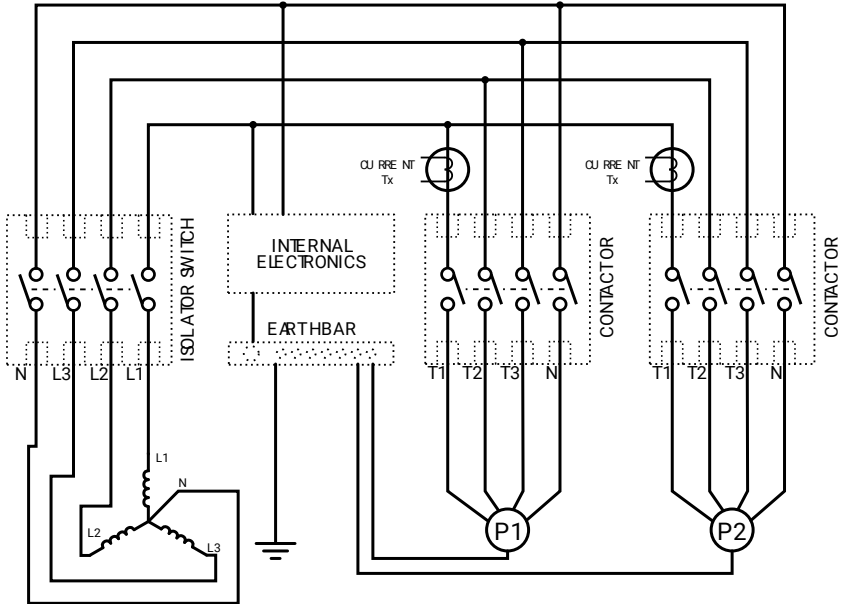

SINGLE PHASE:

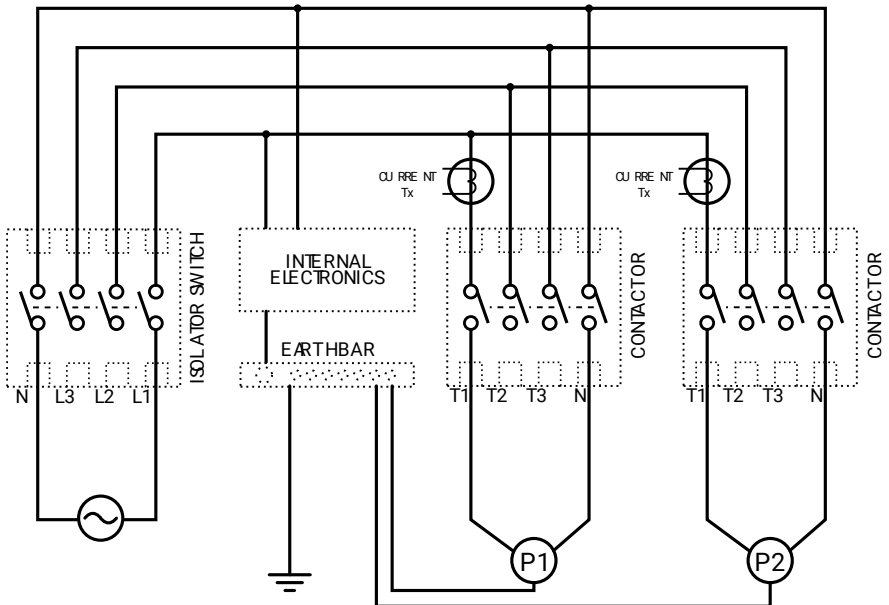

10 Mounting the Product

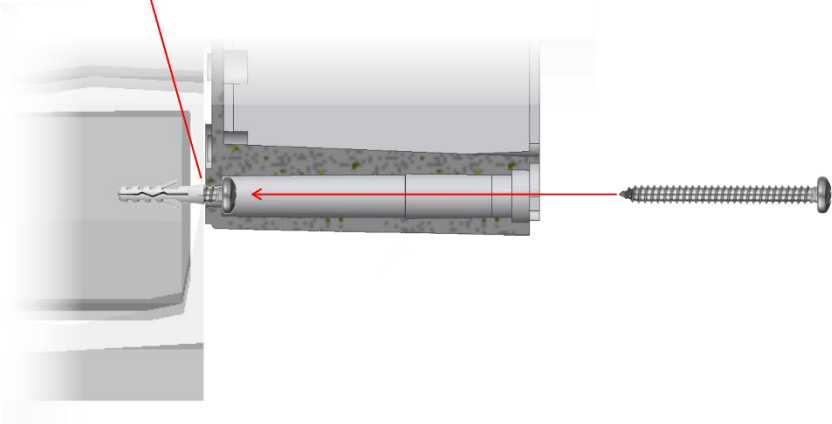
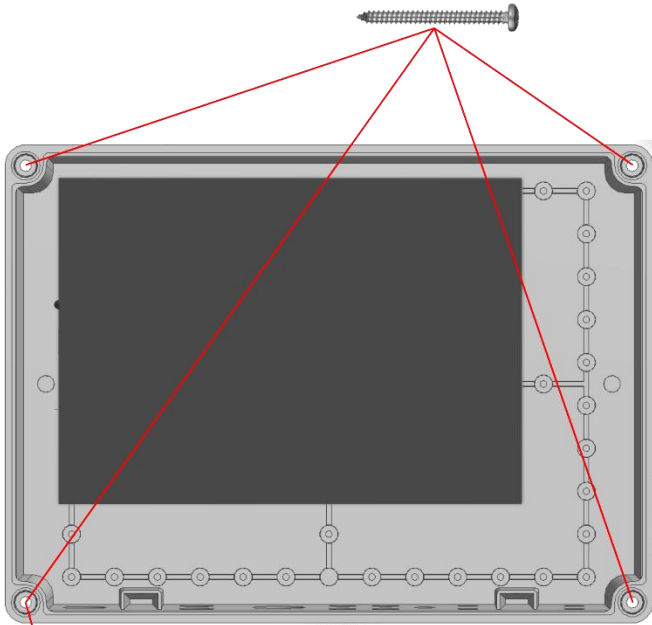

NOTES:**Weather Protection:**

For optimal performance and longevity, install the product in a sheltered location, away from direct exposure to rain, snow, or sunlight. When installing the unit outdoors, the unit should be mounted inside a kiosk or protected by a suitable weather cover.

Mounting Points:

The enclosure includes dedicated mounting points for secure installation. Do not drill or modify the enclosure, as this will compromise its IP rating and void the product warranty.

Mounting surface:

Use a flat, solid wall or surface that can support the full weight of the product and any associated cabling or conduit.

Fasteners:

Use appropriate fixings (e.g., stainless steel screws, wall anchors, or bolts) suitable for the mounting surface and environmental conditions.

Seal inspection:

Check that all gaskets, glands, and covers are properly seated and tightened to maintain the IP rating.

11 Contact Details

Triton Controls Ltd

Randolph Industrial Estate

Evenwood

Bishop Auckland

DL14 9SJ

UK

Tel: +44 (0) 1388 833 000

Email: info@tritoncontrols.co.uk

www.tritoncontrols.co.uk